

Figure 1

CAUTION:
READ AND FOLLOW INSTRUCTIONS CAREFULLY BEFORE PROCEEDING WITH INSTALLATION. DO NOT DEVIATE FROM WIRING INSTRUCTIONS. INCORRECT INSTALLATION COULD CAUSE ELECTRICAL SHORT WITH POSSIBLE FIRE. ALWAYS DISCONNECT BATTERY BEFORE MAKING ANY ELECTRICAL CONNECTIONS.

Refer to your Engine Manual for information on the meaning of the Warning Lights.

NOTE: Engine designs are subject to change. All data shown is based on latest information available at time of publication. Veethree assumes no responsibility for its correctness, or misapplication of its products.

INCLUDED WITH THIS INSTRUMENT

1. Instrument
2. Mounting Bracket Kit
3. Instructions

ADDITIONAL SUPPLIES NEEDED FOR INSTALLATION:

1. Electrical Grease

GAUGE INSTALLATION

1. If there is no hole available in your dash, select a mounting position for the gauge which provides easy readability from the operator's position. Check behind Mounting Panel for installation clearance.
2. Gauge- cut a 2 1/8" (54 mm) diameter hole through the panel at the desired location.
3. Insert gauge through the hole, and secure with "U"-shaped bracket, using nut and washer supplied. Legs of bracket may be shortened if required.

CAUTION:
DO NOT OVER TIGHTEN NUTS, OR YOU MAY CRACK THE GAUGE HOUSING OR THE MOUNTING PANEL.

WIRING CONNECTIONS:

1. Align the 4-pin connector (on pigtail from back of instrument) with matching connector in Engine Wiring Harness. Apply non-insulating electrical grease to connectors. Snap connectors together securely.
2. Connect the Black wire male pin into the Engine Wiring Harness Black wire female receptacle.
3. Connect the Gray wire male pin into the Engine Wiring Harness Gray wire female receptacle.

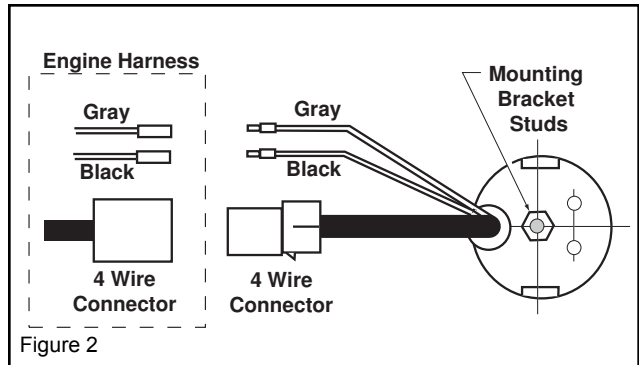

Figure 2

CAUTION:
MAKE SURE THAT ELECTRICAL WIRING IS DRESSED AWAY FROM MOVING OR HOT ENGINE COMPONENTS.

CAUTION:
BEFORE RECONNECTING BATTERY, RECHECK WIRING TO BE SURE ALL CONNECTIONS ARE PROPERLY MADE. INCORRECT CONNECTIONS OR ELECTRICAL SHORTS COULD CAUSE DAMAGE OR FIRE IN SYSTEM. ELEMENTS OF ELECTRICAL SYSTEM SHOULD HAVE PROPER FUSES INSTALLED.

1. When wiring is completed, Connect Battery. **Installation is complete.**

If you require Technical Assistance or Warranty Replacement on this Product, contact your Dealer, or Veethree Technical Service.



USA Sales/Support
 Veethree Electronics and Marine
 2050 47th Terrace East
 Bradenton, FL 34203 USA
 Tel 941-538-7775
 Fax 941-775-1222
 techservice@veethree.com
 www.v3instruments.com